

Threephase heavy duty fork lift truck with enclosed AC motors

Rotating seat (optional) for relaxed operation while reversing

New operating concept with SOLO- or MULTI-PILOT in an armrest that accompanies the arm movement

Curve Control for optimum stability

Automatic parking brake; no rolling back on inclines

Maintenance-free laminated brakes



## EFG 535–550

### Electric four wheel fork lift trucks (3500, 4000, 4500 and 4990 kg)

Using innovative threephase AC technology offers a range of advantages:

- Maximum throughput with peak acceleration, travel and lift levels.
- Longer uptimes through optimum efficiency and more effective energy regeneration.
- Precise control and wear-free regenerative braking by releasing the accelerator pedal and feeding energy back to the battery.

- Maintenance and wear-free enclosed three-phase motors (without carbon brushes) to IP 54 safety rating.

With outstanding travel/lift speeds and excellent acceleration and gradeability, these electric fork lift trucks achieve throughput levels to rival diesel/LPG trucks. The enclosed motor design allows them to be used for both indoor and outdoor applications. Even

extreme application conditions such as dust, chemicals and humidity do not affect the reliability and useful life of the motors.

These threephase AC fork lift trucks are niversally applicable, offer a comfortable operating environment with their exhaust-free and quiet drive systems, and reduce running costs through low energy consumption.

# EFG 535-550

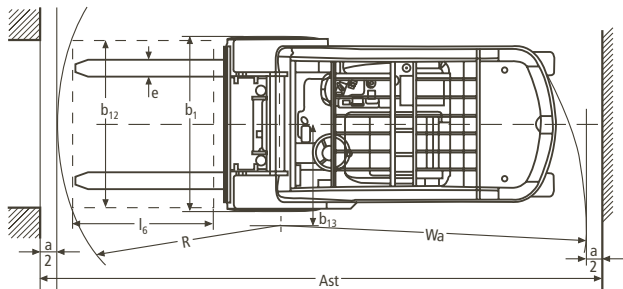
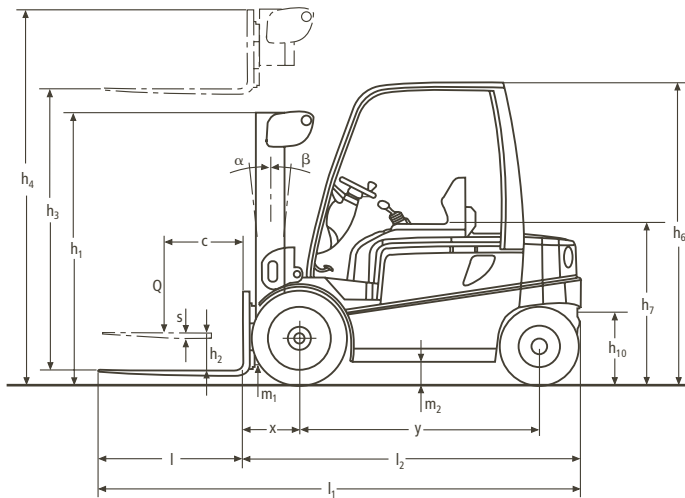

## Capacity

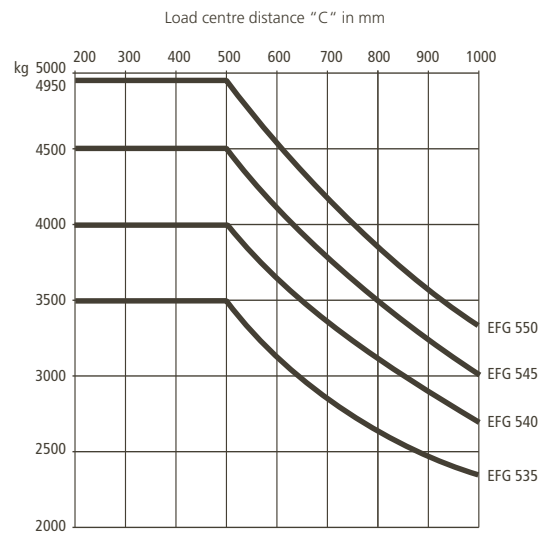

Mast table EFG 535-550										Capacity table (kg) c = 500 mm				
Designation	Lift h <sub>3</sub> (mm)	Free lift h <sub>2</sub> (mm)			Closed height h <sub>1</sub> (mm)		Extended height h <sub>4</sub> (mm)			Tilt forward/ backward α/β (°)	without sideshift, single tyres			
		EFG 535	EFG 540/545	EFG 550	EFG 535	EFG 540-550	EFG 535	EFG 540/545	EFG 550		EFG 535	EFG 540	EFG 545	EFG 550
Two-stage mast ZT	2750		150	150		2280		3580	3580	6/8		4000	4500	4990
	3000		150	150		2405		3830	3830	6/8		4000	4500	4990
	3100	150				2228		3883		6/8	3500			
	3500	150	150	150	2428	2655	4283	4330	4330	6/8	3500	4000	4500	4990
	4000	150	150	150	2678	2905	4783	4830	4830	6/8	3500	4000	4500	4990
	4500	150	150	150	2978	3155	5283	5330	5330	6/8	3500	4000	4500	4990
	5000	150	150	150	3228	3405	5783	5830	5830	6/8	3450	4000	4500	4900
	5500		150	150		3655		6330	6330	6/5		3850	4100	4800
	6000		150	150		3905		6830	6830	6/5		3700		4600
6500		150	150		4155		7330	7330	6/5					
Two-stage mast ZZ	2700		1376	1227		2080		3404	3553	6/8		4000	4500	4990
	2950		1501	1352		2205		3654	3803	6/8		4000	4500	4990
	3450		1751	1602		2455		4154	4303	6/8		4000	4500	4990
	3950		2001	1852		2705		4654	4803	6/8		4000	4500	4990
	4450		2251	2102		2955		5154	5303	6/8		4000	4500	4990
	4950		2501	2352		3205		5654	5803	6/8		4000		4990
	5450		2751	2602		3455		6154	6303	6/5				
Three-stage mast DZ	3800		1376	1227		2080		4504	4653	6/8		4000	4500	4990
	4175		1501	1352		2205		4879	5023	6/8		4000	4500	4990
	4700	1430				2193		5463		6/8	3500			
	4925		1751	1602		2455		5629	5773	6/8		3920	4420	4750
	5000	1530				2293		5763		6/8	3500			
	5300		1871	1727		2580		6004	6153	6/5		3890	4300	4700
	5500	1730				2493		6263		6/5	3100			
	5675		2001	1852		2705		6379	6523	6/5		3750	4200	4610
	6000	1930				2693		6763		6/5	2900			
	6425		2251	2102		2955		7129	7273	6/3		3550	4000	4300
	6500	2130				2893		7263		6/5	2800			
7175		2521	2352		3205		7879	8023	6/3		3200	3200	4000	

# Technical data in line with VDI 2198 as at: 11/2009

Identification	1.1	Manufacturer (abbreviation)	Jungheinrich	Jungheinrich	Jungheinrich	Jungheinrich	1.1	
	1.2	Manufacturer's type designation	<b>EFG 535</b>	<b>EFG 540</b>	<b>EFG 545</b>	<b>EFG 550</b>	1.2	
	1.3	Drive	electric	electric	electric	electric	1.3	
	1.4	Operator type	seat	seat	seat	seat	1.4	
	1.5	Load capacity/rated load	Q (t)	3.5	4	4.5	4.99	1.5
	1.6	Load centre distance	c (mm)	500	500	500	500	1.6
	1.8	Load distance (Centre of load axle to fork face)	x (mm)	480 <sup>1)</sup>	510 <sup>2)</sup>	510 <sup>2)</sup>	510 <sup>2)</sup>	1.8
	1.9	Wheelbase	y (mm)	1855	2000	2000	2000	1.9
	Weights	2.1	Service weight incl. battery (see line 6.5)	kg	5800	6600	6950	7300
2.2		Axle loading, laden front/rear	kg	8350/950	9700/900	10400/1050	11200/1100	2.2
2.3		Axle loading, unladen front/rear	kg	3000/2800	3700/2900	3700/3250	3700/3600	2.3
Wheels, Chassis	3.1	Tyres	Solid	Solid	Solid	Solid	3.1	
	3.2	Tyre size, front	250-15	250-15	250-15	28x12.5-15	3.2	
	3.3	Tyre size, rear	21x8-9	21x8-9	21x8-9	21x8-9	3.3	
	3.5	Wheels, number front rear (x = driven wheels)	2x/2	2x/2	2x/2	2x/2	3.5	
	3.6	Track width, front	b <sub>10</sub> (mm)	1120	1120	1120	1150	3.6
	3.7	Track width, rear	b <sub>11</sub> (mm)	950	950	950	950	3.7
	Basic Dimensions	4.1	Tilt of mast/fork carriage forward/backward	$\alpha/\beta$ (°)	6/8	6/8	6/8	6/8
4.2		Closed mast height	h <sub>1</sub> (mm)	2228	2405	2405	2405	4.2
4.3		Free lift	h <sub>2</sub> (mm)	150	150	150	150	4.3
4.4		Lift (standard mast)	h <sub>3</sub> (mm)	3100	3000	3000	3000	4.4
4.5		Height, mast extended	h <sub>4</sub> (mm)	3883	3830	3830	3830	4.5
4.7		Height of overhead guard (cabin)	h <sub>6</sub> (mm)	2320	2320	2320	2320	4.7
4.8		Seat height/stand height	h <sub>7</sub> (mm)	1165	1165	1165	1165	4.8
4.12		Coupling height	h <sub>10</sub> (mm)	390/550	390/550	390/550	390/550	4.12
4.19		Overall length	l <sub>1</sub> (mm)	3835	3980	3980	3980	4.19
4.20		Length to face of forks	l <sub>2</sub> (mm)	2685	2830	2830	2830	4.20
4.21		Overall width		1340/-	1340/-	1340/-	1450/-	4.21
4.22		Fork dimensions		45/125/1150	50/125/1150	50/150/1150	50/150/1150	4.22
4.23		Fork carriage ISO 2328, class/type A, B		3A	3A	3A	3A	4.23
4.24		Fork-carriage width	b <sub>3</sub> (mm)	1120	1260	1260	1260	4.24
4.31		Ground clearance, laden, below mast	m <sub>1</sub> (mm)	120	120	120	120	4.31
4.32		Ground clearance, centre of wheelbase	m <sub>2</sub> (mm)	160	160	160	160	4.32
4.33	Aisle width for pallets 1000x1200 crossways	Ast (mm)	3980	4160	4160	4160	4.33	
4.34	Aisle width for pallets 800x1200 lengthways	Ast (mm)	4180	4360	4360	4360	4.34	
4.35	Turning radius	Wa (mm)	2300	2450	2450	2450	4.35	
4.36	Internal turning radius	b <sub>13</sub> (mm)	670	670	670	725	4.36	
Performance Data	5.1	Travel speed, laden/unladen	km/h	16/17	15/17	15/16.5	15/16	5.1
	5.2	Lift speed, laden/unladen	m/s	0.38/0.50	0.35/0.47	0.33/0.45	0.31/0.45	5.2
	5.3	Lowering speed, laden/unladen	m/s	0.58/0.55	0.55/0.50	0.55/0.50	0.55/0.50	5.3
	5.5	Drawbar pull, laden/unladen	N	5200/5700	5100/5600	4900/5500	5000/5800	5.5
	5.6	Max. drawbar pull, laden/unladen	N	14700/14900	14600/14900	14500/14800	15100/15500	5.6
	5.7	Gradeability, laden/unladen	%	8.5/14.5	8/13.5	7/12	6.5/12	5.7
	5.8	Max. gradeability, laden/unladen	%	15.5/25	14/23.5	12.5/21.5	12/21	5.8
	5.9	Acceleration time, laden/unladen		4.8/4.2	5.0/4.4	5.5/4.8	5.8/5.2	5.9
	5.10	Service brake		hydraulic	hydraulic	hydraulic	hydraulic	5.10
	E-Motor	6.1	Drive motor rating S <sub>2</sub> 60 min.	kW	18	18	18	18
6.2		Lift motor rating at S <sub>3</sub> 15%	kW	23.5	23.5	23.5	23.5	6.2
6.3		Battery acc. to DIN 43531/35/36 A, B, C, no		43536 A	43536 A	43536 A	43536 A	6.3
6.4		Battery voltage, nominal capacity K5	V/Ah	80/775	80/930	80/930	80/930	6.4
6.5		Battery weight	kg	1863	2178	2178	2178	6.5
6.6		Battery dimensions	mm	1028/855/784	1028/999/784	1028/999/784	1028/999/784	6.6
Others	8.1	Energy consumption acc. to VDI cycle	kWh/h	9.9 <sup>3)</sup>	12.6 <sup>3)</sup>	13.9 <sup>3)</sup>	15.3 <sup>3)</sup>	6.6
	8.1	Type of drive control		Impulse/AC	Impulse/AC	Impulse/AC	Impulse/AC	8.1
	8.2	Operating pressure for attachments	bar	200	200	200	200	8.2
	8.3	Oil volume for attachments	l/min	30	30	30	30	8.3
	8.4	Sound level at the driver's ear according to EN 12053		75	75	75	75	8.4
8.5	Towing coupling, type DIN		DIN 15170 H	DIN 15170 H	DIN 15170 H	DIN 15170 H	8.5	

1) 505 mm for DZ mast; for integrated sideshift: x = 494 mm (DZ mast 519 mm); for sideshift attachment: x = 552 mm (577 mm on DZ mast)  
 2) 541 mm for DZ mast; for integrated sideshift: x = 542 mm (573 mm for DZ mast); for sideshift attachment: x = 582 mm (613 mm on DZ mast)  
 3) 60 working cycles/h

# Make use of the advantages

## Comfortable workplace

The ergonomic operator position ensures relaxed, fatigue-free operation over long shifts:

- Low entry height with a step that is easily visible from above. Large, level footwell with automotive-type pedals.
- Adjustable steering column and adjustable comfort seat for optimum seating position.
- Clear view: mast and fork carriage offer a particularly wide field of vision.
- Hydraulic power steering: easy to operate.
- Particularly comfortable operation with all the main controls incorporated in the arm-rest that accompanies the arm movement (height and length are adjustable).
- Limited vibration as the cab is not connected to the chassis (floating cab).
- Relaxed operation even when reversing with the rotating seat device (optional). Rotating seat can swivel up to 15°.



Rotating seat (optional)



SOLO-PILOT

## Wear-free brakes – automatic parking brake

Three brake systems ensure safe, comfortable and predominantly wear-free braking:

- Motor brake for wear-free regenerative braking via the accelerator pedal in normal travel mode.

- Oil immersed laminated brake acts as safety brake. Wear-free and fully enclosed.
- Electric spring pressure brake acts as parking brake. The brake applies automatically when the truck is stationary and releases again when it starts up. This prevents the truck from rolling away accidentally.

## Maintenance-free motors

Three-phase AC technology across the board: drive motor, hydraulic motor, steer motor:

- High torque for fast working cycles.
- 15 % more efficient than shunt-wound motors.
- In many cases a single battery charge can cover two shifts.
- No carbon brushes, no collector – no maintenance.
- Fully enclosed to IP 54. Maximum useful life even when operating in dusty and humid environments.
- 2 year warranty on all motors.

## Safety

Outstanding travel dynamics and performance levels also require a high level of safety:

- Automatic travel speed reduction when cornering with Curve Control.

- No accidental rolling back on ramps/inclines with automatic parking brake.
- Safe handling with long wheel base.
- Electronic and hydraulic overload protection.
- Safe data transmission between the electronic components with CAN-Bus technology.
- Maximum stability through extremely low centre of gravity and high mounted steer axle.



Drivers display

## Intelligent electronics

- Smooth travel, dynamic reversing and pinpoint positioning with minimal energy consumption through impulse electronic control system.
- Optimum adaptation to every application with five individually adjustable operating programmes.
- Monitoring of all components and service data storage for rapid and cost-effective diagnostic system maintenance.
- Drivers display with digital hourmeter, battery discharge indicator with lift cut-out, time, error code and warning displays.
- Steering wheel position display.

## Jungheinrich UK Ltd.

Head Office:

Sherbourne House · Sherbourne Drive  
Tilbrook · Milton Keynes MK7 8HX  
Phone 01908 363100  
Fax 01908 363180

info@jungheinrich.co.uk  
www.jungheinrich.co.uk



Jungheinrich trucks conform to the European Safety Requirements.

**JUNGHEINRICH**  
Well worthwhile