

**Threephase heavy duty fork lift truck
with enclosed AC motors**

**Rotating seat (optional) for relaxed
operation while reversing**

**New operating concept
with SOLO- or MULTI-PILOT
in an armrest that accompanies
the arm movement**

Curve Control for optimum stability

**Automatic parking brake;
no rolling back on inclines**

**Maintenance-free
laminated brakes**



EFG 425–430

Electric four wheel fork lift trucks (2500 and 3000 kg)

Using innovative threephase AC technology offers a range of advantages:

- Maximum throughput with peak acceleration, travel and lift levels.
- Longer uptimes through optimum efficiency and more effective energy regeneration.
- Precise control and wear-free regenerative braking by releasing the accelerator pedal and feeding energy back to the battery.

- Maintenance and wear-free enclosed threephase motors (without carbon brushes) to IP 54 safety rating.

With outstanding travel/lift speeds and excellent acceleration and gradeability, these electric fork lift trucks achieve throughput levels to rival diesel/LPG trucks. The enclosed motor design allows them to be used for both indoor and outdoor applications. Even extreme application con-

ditions such as dust, chemicals and humidity do not affect the reliability and useful life of the motors.

These threephase AC fork lift trucks are universally applicable, offer a comfortable operating environment with their exhaust-free and quiet drive systems, and reduce running costs through low energy consumption.

EFG 425–430

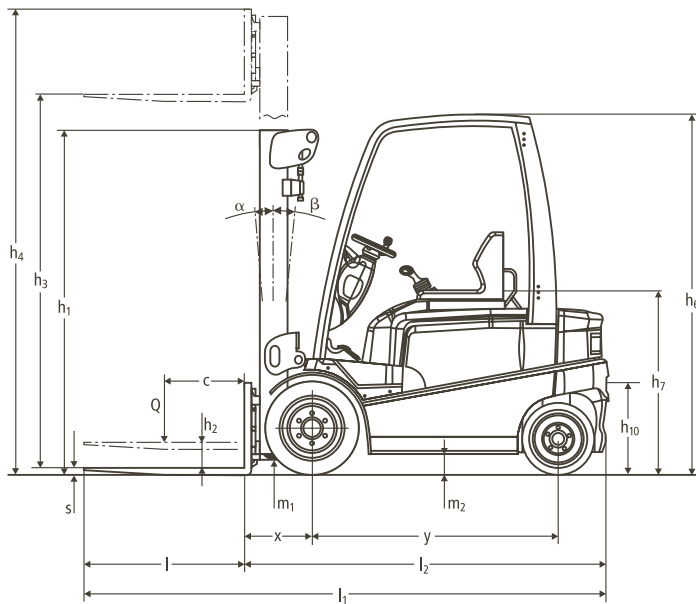

Capacity

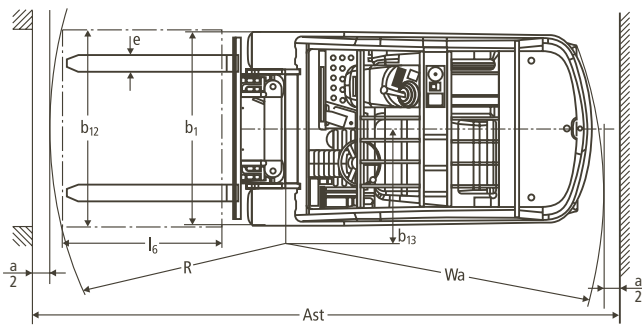
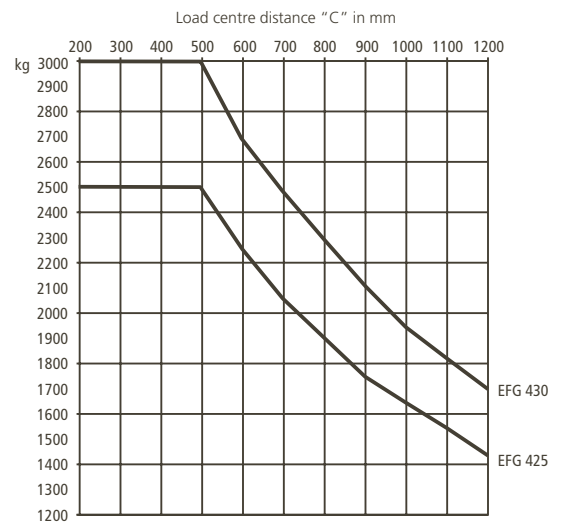

Mast table EFG 425–430							Capacity table (kg) c = 500 mm		
Designation	Lift height h ₃ mm	Free lift h ₂ mm		Closed height h ₁ mm	Extended height h ₄ mm		Tilt forward/ backward α/β (°)	without sideshift, single tyres	
		EFG 425	EFG 430		EFG 425	EFG 430		EFG 425	EFG 430
Two-stage mast ZT	2900	150	150	2115	3510	3620	6/8	2500	3000
	3100	150	150	2215	3710	3820	6/8	2500	3000
	3300	150	150	2315	3910	4020	6/8	2500	3000
	3500	150	150	2415	4110	4220	6/8	2500	3000
	3700	150	150	2515	4310	4420	6/8	2500	3000
	4000	150	150	2665	4610	4720	6/8	2500	3000
	4300	150	150	2865	4910	5020	6/8	2500	3000
	4500	150	150	2965	5110	5220	6/8	2500	3000
	4700	150	150	3065	5310	5420	6/5	2450	2900
	5000	150	150	3215	5610	5720	6/5	2400	2800
	5500	150	150	3515	6110	6220	6/5	2200	2550
5800	150	150	3665	6410	6520	6/5	2050	2400	
Two-stage mast ZZ	2900	1480	1380	2080	3500	3600	6/8	2500	3000
	3100	1580	1480	2180	3700	3800	6/8	2500	3000
	3300	1680	1580	2280	3900	4000	6/8	2500	3000
	3500	1780	1680	2380	4100	4200	6/8	2500	3000
	3700	1880	1780	2480	4300	4400	6/8	2500	3000
	4000	2030	1930	2630	4600	4700	6/8	2500	3000
	4300	2230	2130	2830	4900	5000	6/8	2500	3000
4500	2330	2230	2930	5100	5200	6/8	2300	3000	
Three-stage mast DZ	4400	1480	1380	2080	5000	5100	6/8	2500	3000
	4700	1580	1480	2180	5300	5400	6/5	2450	2900
	5000	1680	1580	2280	5600	5700	6/5	2400	2800
	5500	1880	1780	2480	6100	6200	6/5	2150	2500
	6000	2080	1980	2680	6600	6700	6/5	1900	2200
	6500	2280	2180	2880	7100	7200	6/3	1700	2000
	7000	2480	2380	3080	7600	7700	6/3	1500	1800

Technical data in line with VDI 2198 as at: 11/2009

Identification	1.1	Manufacturer (abbreviation)	Jungheinrich	Jungheinrich	Jungheinrich	Jungheinrich	Jungheinrich	1.1	
	1.2	Manufacturer's type designation	EFG 425 k	EFG 425	EFG 425 ks	EFG 425 s	EFG 430	1.2	
	1.3	Drive	electric	electric	electric	electric	electric	1.3	
	1.4	Operator type	seat	seat	seat	seat	seat	1.4	
	1.5	Load capacity/rated load	Q (t)	2.5	2.5	2.5	2.5	3	1.5
	1.6	Load centre distance	c (mm)	500	500	500	500	500	1.6
	1.8	Load distance (Centre of load axle to fork face) x (mm)		425 ¹⁾	425 ¹⁾	425 ¹⁾	425 ¹⁾	430 ²⁾	1.8
	1.9	Wheelbase	y (mm)	1537	1681	1537	1681	1681	1.9
	Weights	2.1	Service weight incl. battery (see line 6.5)	kg	4600	4750	4600	4750	5100
2.2		Axle loading, laden front/rear	kg	6300/800	6400/850	6300/800	6400/850	7250/850	2.2
2.3		Axle loading, unladen front/rear	kg	2300/2300	2530/2220	2300/2300	2530/2220	2600/2500	2.3
Wheels, Chassis	3.1	Tyres		SE	SE	SE	SE	SE	3.1
	3.2	Tyre size, front		23x9-10	23x9-10	23x9-10	23x9-10	23x10-12	3.2
	3.3	Tyre size, rear		18x7-8	18x7-8	18x7-8	18x7-8	18x7-8	3.3
	3.5	Wheels, number front rear (x = driven wheels)		2x/2	2x/2	2x/2	2x/2	2x/2	3.5
	3.6	Track width, front	b ₁₀ (mm)	990	990	990	990	956	3.6
	3.7	Track width, rear	b ₁₁ (mm)	920	920	920	920	920	3.7
	Basic Dimensions	4.1	Tilt of mast/fork carriage forward/backward	α/β (°)	6/8	6/8	6/8	6/8	6/8
4.2		Closed mast height	h ₁ (mm)	2215	2215	2215	2215	2215	4.2
4.3		Free lift	h ₂ (mm)	150	150	150	150	150	4.3
4.4		Lift (standard mast)	h ₃ (mm)	3100	3100	3100	3100	3100	4.4
4.5		Height, mast extended	h ₄ (mm)	3710	3710	3710	3710	3820	4.5
4.7		Height of overhead guard (cabin)	h ₆ (mm)	2215	2215	2215	2215	2215	4.7
4.8		Seat height/stand height	h ₇ (mm)	1060	1060	1060	1060	1060	4.8
4.12		Coupling height	h ₁₀ (mm)	390/550	390/550	390/550	390/550	390/550	4.12
4.19		Overall length	l ₁ (mm)	3428	3572	3428	3572	3577	4.19
4.20		Overall length (without load)	l ₂ (mm)	2278	2422	2278	2422	2427	4.20
4.21		Overall width		1196/-	1196/-	1196/-	1196/-	1196/-	4.21
4.22		Fork dimensions		40/120/1150	40/120/1150	40/120/1150	40/120/1150	45/125/1150	4.22
4.23		Fork carriage ISO 2328, class/type A, B		ISO 2A	ISO 2A	ISO 2A	ISO 2A	ISO 3A	4.23
4.24		Fork-carriage width	b ₃ (mm)	1120	1120	1120	1120	1120	4.24
4.31		Ground clearance, laden, below mast	m ₁ (mm)	110	110	110	110	110	4.31
4.32		Ground clearance, centre of wheelbase	m ₂ (mm)	125	125	125	125	125	4.32
4.33	Aisle width for pallets 1000x1200 crossways	Ast (mm)	3675	3825	3675	3825	3830	4.33	
4.34	Aisle width for pallets 800x1200 lengthways	Ast (mm)	3875	4025	3875	4025	4030	4.34	
4.35	Turning radius	Wa (mm)	2050	2200	2050	2200	2200	4.35	
4.36	Internal turning radius	b ₁₃ (mm)	650	695	650	695	695	4.36	
Performance Data	5.1	Travel speed, laden/unladen	km/h	17/18	17/17	20/20	20/20	20/20	5.1
	5.2	Lift speed, laden/unladen	m/s	0.44/0.54	0.44/0.54	0.55/0.60	0.55/0.60	0.50/0.60	5.2
	5.3	Lowering speed, laden/unladen	m/s	0.58/0.56	0.58/0.56	0.58/0.56	0.58/0.56	0.58/0.56	5.3
	5.5	Drawbar pull, laden/unladen	N	3600/4000	3500/3900	5200/5500	5100/5500	4800/5300	5.5
	5.6	Max. drawbar pull, laden/unladen	N	12300/12700	12200/12600	14500/15000	14500/15000	14000/14500	5.6
	5.7	Gradeability, laden/unladen	%	8.5/14	7.5/13	12/19	11/17	10/17	5.7
	5.8	Max. gradeability, laden/unladen	%	18/29	17/27	21/35	20/32	18/29	5.8
	5.9	Acceleration time, laden/unladen		4.3/4.0	4.4/4.1	4.1/3.7	4.1/3.7	4.2/3.8	5.9
	5.10	Service brake		hydraulic	hydraulic	hydraulic	hydraulic	hydraulic	5.10
	E-Motor	6.1	Drive motor rating S ₂ 60 min.	kW	11	11	14.5	14.5	14.5
6.2		Lift motor rating at S ₃ 15%	kW	16	16	23.5	23.5	23.5	6.2
6.3		Battery acc. to DIN 43531/35/36 A, B, C, no		DIN 43536 A	DIN 43536 A	DIN 43536 A	DIN 43536 A	DIN 43536 A	6.3
6.4		Battery voltage, nominal capacity K ₅	V/Ah	80/620	80/775	80/620	80/775	80/775	6.4
6.5		Battery weight	kg	1575	1855	1575	1855	1855	6.5
6.6		Battery dimensions	mm	1028/711/784	1028/855/784	1028/711/784	1028/855/784	1028/855/784	
Others	8.1	Energy consumption acc. to VDI cycle	kWh/h	7.5 ³⁾	7.6 ³⁾	7.6 ³⁾	7.7 ³⁾	8.4 ³⁾	6.6
	8.1	Type of drive control		Impulse/AC	Impulse/AC	Impulse/AC	Impulse/AC	Impulse/AC	8.1
	8.2	Operating pressure for attachments	bar	200	200	200	200	200	8.2
	8.3	Oil volume for attachments	l/min	30	30	30	30	30	8.3
	8.4	Sound level at the driver's ear according to EN 12 053		70	70	71	71	71	8.4
8.5	Towing coupling, type DIN		DIN 15170-H	DIN 15170-H	DIN 15170-H	DIN 15170-H	DIN 15170-H	8.5	

1) 452 mm for DZ mast; for integrated sideshift: x = 437 mm
 2) 457 mm for DZ mast; for integrated sideshift: x = 444 mm
 3) 60 VDI working cycles/h

Make use of the advantages

Comfortable workplace

The ergonomic operator position ensures relaxed, fatigue-free operation over long shifts:

- Low entry height. Large, level footwell with automotive-type pedals.
- Adjustable steering column and adjustable comfort seat for optimum seating position.
- Clear view: mast and fork carriage offer a particularly wide field of vision.
- Hydraulic power steering.
- Particularly comfortable operation with all the main controls incorporated in the armrest that accompanies the arm movement (height and length are adjustable).
- Limited vibration as the cab is not connected to the chasis (floating cab).
- Relaxed operation even when reversing with seat that can rotate by up to 15° (optional).



SOLO-PILOT

Wear-free brakes – automatic parking brake

Three brake systems ensure safe, comfortable and predominantly wear-free braking:

- Motor brake for wear-free regenerative braking via the accelerator pedal in normal travel mode.
- Oil immersed laminated brake acts as safety brake. Wear-free and fully enclosed.
- Electric spring pressure brake acts as parking brake. The brake applies automatically when the truck is stationary and releases again when it starts up. This prevents the truck from rolling away accidentally.

Maintenance-free motors

Three-phase AC technology across the board: drive motor, hydraulic motor, steer motor.

- High torque for fast working cycles.
- 15% more efficient than shunt-wound motors.
- In many cases a single battery charge can cover two shifts.
- No carbon brushes, no collector – no maintenance.
- Fully enclosed to IP 54. Maximum useful life even when operating in dusty and humid environments.
- 2 year warranty on all motors.

Safety

Outstanding travel dynamics and performance levels also require a high level of safety:

- Automatic travel speed reduction when cornering with Curve Control.
- No accidental rolling back on ramps/inclines with automatic parking brake.
- Safe handling with long wheel base.
- Electronic and hydraulic overload protection.
- Safe data transmission between the electronic components with CAN-Bus technology.



Rotating seat (optional)

- Maximum stability through extremely low centre of gravity and high mounted steer axle.

Intelligent electronics

- Smooth travel, dynamic reversing and pinpoint positioning with minimal energy consumption through impulse electronic control system.
- Optimum adaptation to every application with five individually adjustable operating programmes.
- Monitoring of all components and service data storage for rapid and cost-effective diagnostic system maintenance.
- Drivers display with digital hourmeter, battery discharge indicator with lift cut-out, time, error code and warning displays.
- Steering wheel position display.

Jungheinrich UK Ltd.

Head Office:

Sherbourne House · Sherbourne Drive
Tilbrook · Milton Keynes MK7 8HX
Phone 01908 363100
Fax 01908 363180

info@jungheinrich.co.uk
www.jungheinrich.co.uk



JUNGHEINRICH
Well worthwhile