

Exceptionally quiet operation

Unique operating element

Short and manoeuvrable

Robust and durable

Fast lift optional



AM 22

Hand pallet truck (2200 kg)

The hand pallet truck AM 22 is the ideal "storage aid" for all manual transport tasks over short distances. Here all its advantages are effectively utilised:

- For left as well as right handers equally comfortable and easy to handle operating element. Effortless and safe manoeuvring with one hand on the tiller head.

- Optional fast lift (up to 120 kg) for ground clear lifting of pallets with only three pump actions.
- Excellent manoeuvrability even in the most confined spaces through narrow fore-structure.

Chromed bearing bushes on wheels and joints make for easy pulling or pushing.

They are convincing with their remarkably quiet running and maintenance free operation. Several selectable roller coatings ensure optimum operation on most dissimilar floors.

AM 22

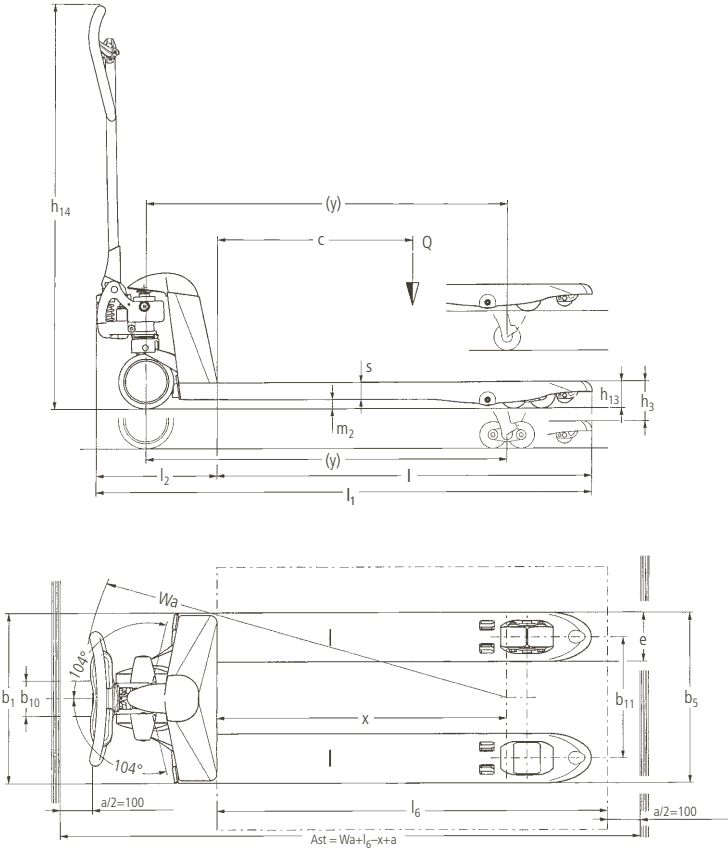

Technical Data in line with VDI 2198 as at: 02/2009

Identification	1.1	Manufacturer (abbreviation)	Jungheinrich	Jungheinrich	Jungheinrich	Jungheinrich	Jungheinrich	Jungheinrich	1.1	
	1.2	Manufacturer's type designation	AM 22	AM 22	AM 22	AM 22	AM 22	AM 22	1.2	
			(795 mm)	(950 mm)	(1054 mm)	(1150 mm)	(1207 mm) ⁷⁾	(1207 mm)		
	1.4	Type of operation	manual	manual	manual	manual	manual	manual	1.4	
	1.5	Load capacity/rated load	Q (t)	2.2	2.2	2.2	2.2	2.2	1.5	
	1.6	Load centre distance	c (mm)	400	500	534	600	610	610	1.6
	1.8	Load distance, centre of drive axle to fork	x (mm)	535	690	794	890	947	947	1.8
	1.9	Wheelbase	y (mm)	755	910	1014	1110	1167	1167	1.9
Weights	2.1	Service weight	kg	51 ⁹⁾	54 ⁸⁾	56 ⁶⁾	58 ²⁾	59 ¹⁾	59 ¹⁾	2.1
	2.3	Axle loading, unladen front/rear	kg				38/20 ³⁾	39/20 ³⁾		2.3
Wheels, Chassis	3.1	Tyres	C; V; N	C; V; N	C; V; N	C; V; N	C; V; N	C; V; N	C; V; N	3.1
	3.2	Tyre size, front		170	170	170	170	170	170	3.2
	3.3	Tyre size, rear		82x96/82x62 ⁴⁾	82x96/82x62 ⁴⁾	82x96/82x62 ⁴⁾	82x96/82x62 ⁴⁾	75x96/75x62 ³⁾	82x96/82x62 ⁴⁾	3.3
	3.5	Wheels, number front/rear (x = driven wheels)		2/2 or 2/4	2/2 or 2/4	2/2 or 2/4	2/2 or 2/4	2/2 or 2/4	2/2 or 2/4	3.5
	3.6	Track width, front	b ₁₀ (mm)	109	109	109	109	109	109	3.6
	3.7	Track width, rear	b ₁₁ (mm)	370	370	370	370	370	370	3.7
Basic Dimensions	4.4	Lift height	h ₃ (mm)	122	122	122	122	124	122	4.4
	4.9	Height of tiller in drive position min./max.	h ₁₄ (mm)	1234	1234	1234	1234	1234	1234	4.9
	4.14	Standing height, elevated	h ₁₂ (mm)	205	205	205	205	199	205	4.14
	4.15	Lowered height	h ₁₃ (mm)	83	83	83	83	75	83	4.15
	4.19	Overall length	l ₁ (mm)	1165	1320	1424	1520	1577	1577	4.19
	4.20	Length to face of forks	l ₂ (mm)	373	373	373	373	373	373	4.20
	4.21	Overall width	b ₁ /b ₂ (mm)	520/680	520/680	520/680	520/680	520/680	520/680	4.21
	4.22	Fork dimensions	s/e/l (mm)	53/150/795	53/150/950	53/150/1054	53/150/1150	53/150/1207	53/150/1207	4.22
	4.25	Width over forks	b ₅ (mm)	520/680	520/680	520/680	520/680	520/680	520/680	4.25
	4.32	Ground clearance, centre of wheelbase	m ₂ (mm)	30	30	30	30	27	30	4.32
	4.33	Aisle width for pallets 1000x1200 crossways	Ast (mm)	1584	1584	1638	1734	1791	1791	4.33
	4.34	Aisle width for pallets 800x1200 lengthways	Ast (mm)	1784	1784	1784	1784	1791	1791	4.34
	4.35	Turning radius	Wa (mm)	919	1074	1178	1274	1331	1331	4.35
Performance Data	5.3	Lowering speed, laden/unladen	m/s	0.09/0.02	0.09/0.02	0.09/0.02	0.09/0.02	0.09/0.02	0.09/0.02	5.3

- 1) 64 kg at 680 mm width over forks
- 2) 63 kg at 680 mm width over forks
- 3) width 520 mm
- 4) 82 x 62 tandem tyres
- 5) 75 x 62 tandem tyres
- 6) 61 kg at 680 mm width over forks
- 7) h₁₃ = 75 mm
- 8) 54 kg at 680 mm width over forks
- 9) 56 kg at 680 mm width over forks

Make use of the advantages

Easy to handle

The convenient operating element is ideally suitable for both left and right handers. Exceptionally sensitive or proportioned lowering of loads through special lowering valve. The optional fast lift (up to 120 kg) ensures ground-clear lifting of Euro pallets with only three pump actions. The maximum lift height is reached after only five pump actions.



The operating element can be used from any position

Shorter and more manoeuvrable

The fore-structure length of 373 mm facilitates safe and effortless operation even in the most confined spaces.

Effortless and simple

The further optimised hydraulic system reduces the required pumping action. Ball bearing wheels reduce the required tractive power.



Maintenance-free hydraulics

Quiet running and robust

The chromed bearing bushes and joints ensure quiet running properties and particularly long service life. It is no longer necessary to lubricate connections; the AM 22 operates like "grease lightning" all the same.



Permanently lubricated connections for maintenance-free operation

Accurate and safe

For crossways pallet pick-up, the embossed marking indicates the exact, safe pallet position.

Long-lasting

Stronger forks. Rounded forms. Welded tiller mounting. Protected entry rollers. More hardened steel. First-rate guarantees for maximum stability and durability. 2200 kg capacity in the basic version speaks for itself!



Rounded fork tips for easier pallet entry

Additional and special equipment

Extensive additional equipment make the AM 22 fit for any application. For example, various fork lengths, diverse widths over forks, different braking systems or special paint. Also available are special types, such as special steel trucks or galvanised truck variants.

Jungheinrich UK Ltd.

Head Office:

Sherbourne House · Sherbourne Drive
Tilbrook · Milton Keynes MK7 8HX
Phone 01908 363100
Fax 01908 363180

info@jungheinrich.co.uk
www.jungheinrich.co.uk

Jungheinrich AG
ISO 9001, ISO 14001
Certification of Quality and
Environment Management.



Jungheinrich trucks
conform to the European
Safety Requirements.



JUNGHEINRICH
Well worthwhile